

qPublic.net™ Christian County, KY PVA

Summary

Map Number/Account Number 240-00 02 005.00 / 162641004
Tax District City of Hopkinsville (01)
Description 107 COUNTRY CLUB LN L4E
 (Note: Not to be used on legal documents)
Tax Rates [See Tax Rates](#)
Location Address 107 COUNTRY CLUB LN
Deed Book WB77
Deed Page 543

[View Map](#)



Owner

[Dew William C Jr &](#)
 Julea Lawson
 4048 Hickory Fairway Dr
 Woodstock GA 30188

Value Information

	2022 Working Tax Roll Assessment	2021 Certified Tax Roll Assessment
Residential Value	\$150,000	\$150,000
Commercial Value	\$0	\$0
Mobile Home Value	\$0	\$0
Farm Tax Value	\$0	\$0
Farm Fair Cash Value	\$0	\$0
TC Build Value	\$0	\$0
TC Land Value	\$0	\$0
LS Hold Value	\$0	\$0
Homestead	No	No

Most Recent Sale

Sale Date	Sale Price	Deed Book	Deed Page	Previous Owner
11/24/2020	\$0	WB77	543	DEW VONDA P

Land Information

Class	RESIDENTIAL	Sidewalks	
Lot Size	0	Topography	
Frontage	0	Zoning Code	
Depth	0	Subdivision	
Acreage	0	Unit	
Type	RESIDENTIAL	Block	
Drive Type	A	Lot	
Flood Type	S	Land Value	\$0
Utility Type	W		

Residential Improvement Information

Res Type	SINGLE FMLY	Heat	GAS
Year Built	0	AC	CENTRAL
Foundation	BRICK ON BLOCK	Total Rooms	0
Basement	NONE	Value	\$0
Exterior	BRICK	Living Sqft	2069
Bedrooms	3	Basement Sqft	0
Full Bath	1	Garage Sqft	725
Half Bath	1	Porch Sqft	0
Roof Cover	CPSN SHGLS	Patio/Deck Sqft	0
Roof Type	HIP	Basement Finish	0
Res Cond		Structure	1 STORY
Fireplaces	1	Garage	ATTCHD 2 CAR

Sale Information

Sale Date	Sale Price	Deed Book	Deed Page	Previous Owner
11/24/2020	\$0	WB77	543	DEW VONDA P

Recent Sales In Area

Sale date range:

From:

01/01/2013



To:

01/14/2022



Photos



Sketches

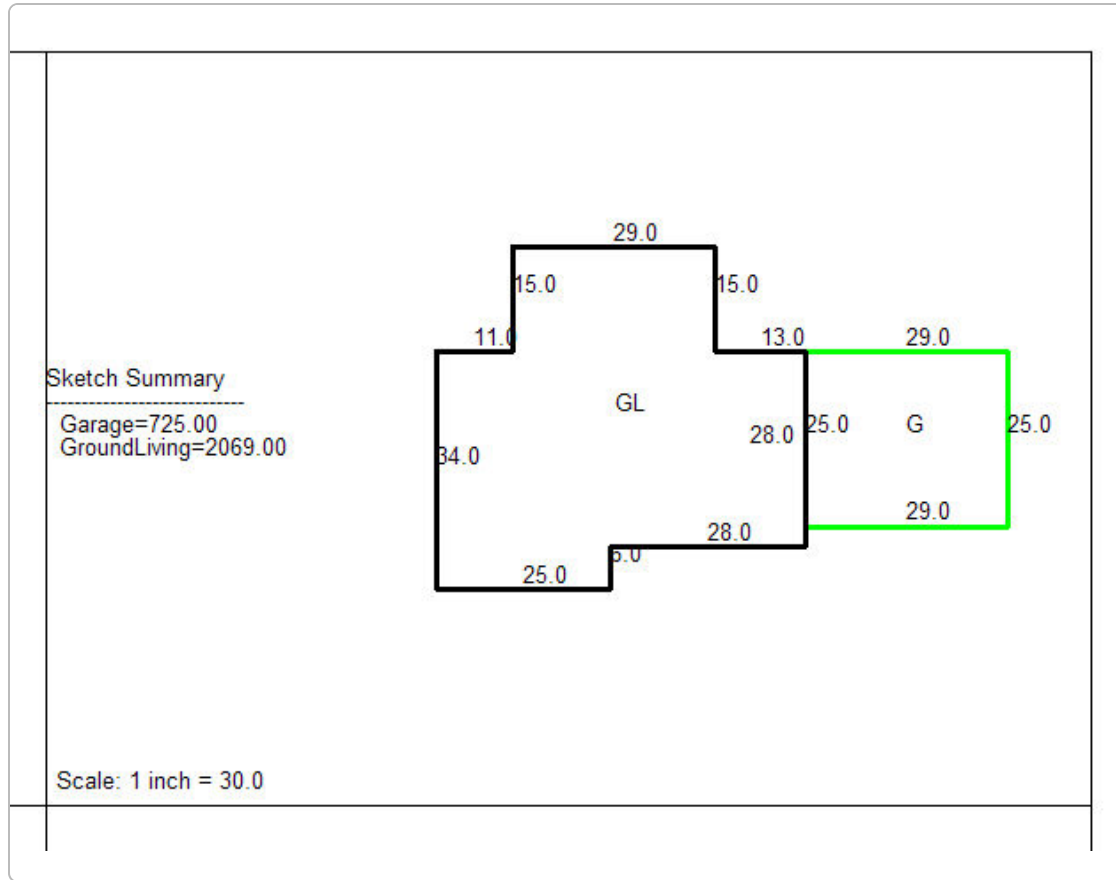

No data available for the following modules: Mobile Home Information, Commercial Information.

[User Privacy Policy](#)
[GDPR Privacy Notice](#)

[Last Data Upload: 1/13/2022, 4:33:23 PM](#)

